

# Surface Mount Ball Bearing Assemblies

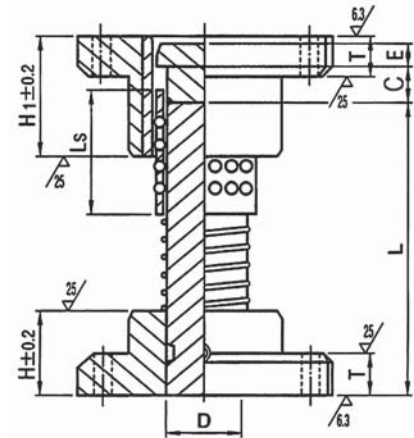

**Anchor Danly**  
The Brands You Trust

# Surface Mount Ball Bearing Guide Post Assembly

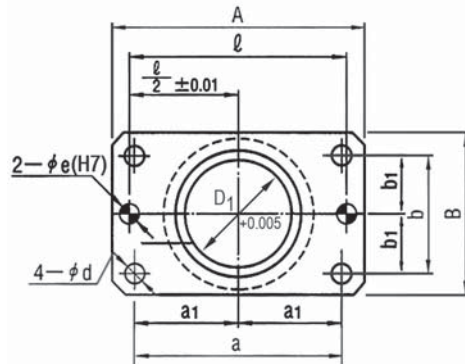

## TAPPING FOR FIXING STROKE END BLOCK

D	M	t1	S
32	4	12	45
38	5	15	60
50	6	15	72
60	8	20	92

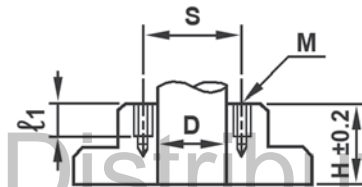

- NOTES:**
- ◆ Add "M" to end of part number to designate mounting holes option for optional stroke end blocks.
  - ◆ Assemblies are supplied with mounting bolts and dowel pins.

Anchor Darty Part Number	D	L	D1	A	B	a	b	d	H	H1	T	C	E	Ls	I	a1	b1	e(H7)	Mounting Bolts	Dowel Pins
ADGPS32X110	32	110	40	100	58	76	36	11	40	60	20	25	5	60	76	38	18	8	10 - 40	8 - 30
ADGPS32X120		120																		
ADGPS32X130		130																		
ADGPS32X140		140																		
ADGPS32X150		150																		
ADGPS32X160		160																		
ADGPS32X170		170																		
ADGPS38X130	38	130	48	130	75	100	44	11	50	70	25	30	10	70	100	50	22	10	10 - 45	10 - 40
ADGPS38X140		140																		
ADGPS38X150		150																		
ADGPS38X160		160																		
ADGPS38X170		170																		
ADGPS38X180		180																		
ADGPS38X200		200																		
ADGPS38X220		220																		
ADGPS38X240		240																		
ADGPS38X260		260																		
ADGPS38X300		300																		
ADGPS50X170	50	170	60	155	90	125	60	14	65	90	25	40	10	90	125	62.5	30	10	12 - 50	10 - 40
ADGPS50X180		180																		
ADGPS50X200		200																		
ADGPS50X220		220																		
ADGPS50X240		240																		
ADGPS50X260		260																		
ADGPS50X300		300																		
ADGPS50X350		350																		
ADGPS60X200	60	200	70	190	120	150	80	18	75	100	30	50	15	100	150	75	40	13	16 - 60	13 - 50
ADGPS60X220		220																		
ADGPS60X240		240																		
ADGPS60X260		260																		
ADGPS60X280		280																		
ADGPS60X300		300																		
ADGPS60X350		350																		

# Selection Guide

## Selection Guide for Anchor Danly Surface Mount Guide Post System

The following points should be considered when selecting Surface Mounted Ball Bearing Assemblies:

- ◆ At the bottom of the press stroke (**BDC**), the length of the preloaded ball bearing engagement should be equal to or greater than the guide post diameter (**D**) for proper guidance and stability (Fig. 6).
- ◆  $h_2 = L + C + E + 10\text{mm}$  (Fig 1) – 10mm is to allow for regrinding and safety considerations. For **C + E**, see Page 2.
- ◆ How to determine **K** (minimum Punch Holder thickness): Reference (Fig. 1) and the blue chart (Page 4).
- ◆ Example: If  $h = 190\text{mm}$  and you select an ADGPS38X200 assembly, from the blue table (Page 4), ADGPS38X200 would have an  $h_2$  dimension of 250mm.  $250\text{mm} - 190\text{mm} (h) = 60\text{mm}$ . **K** is required to be 60mm or greater.
- ◆ As shown in (Fig. 3), select guide post length so ( $h$ ) includes as much contact length (**PL**) as possible.

Use the figures below for reference when using the tables on Page 4.

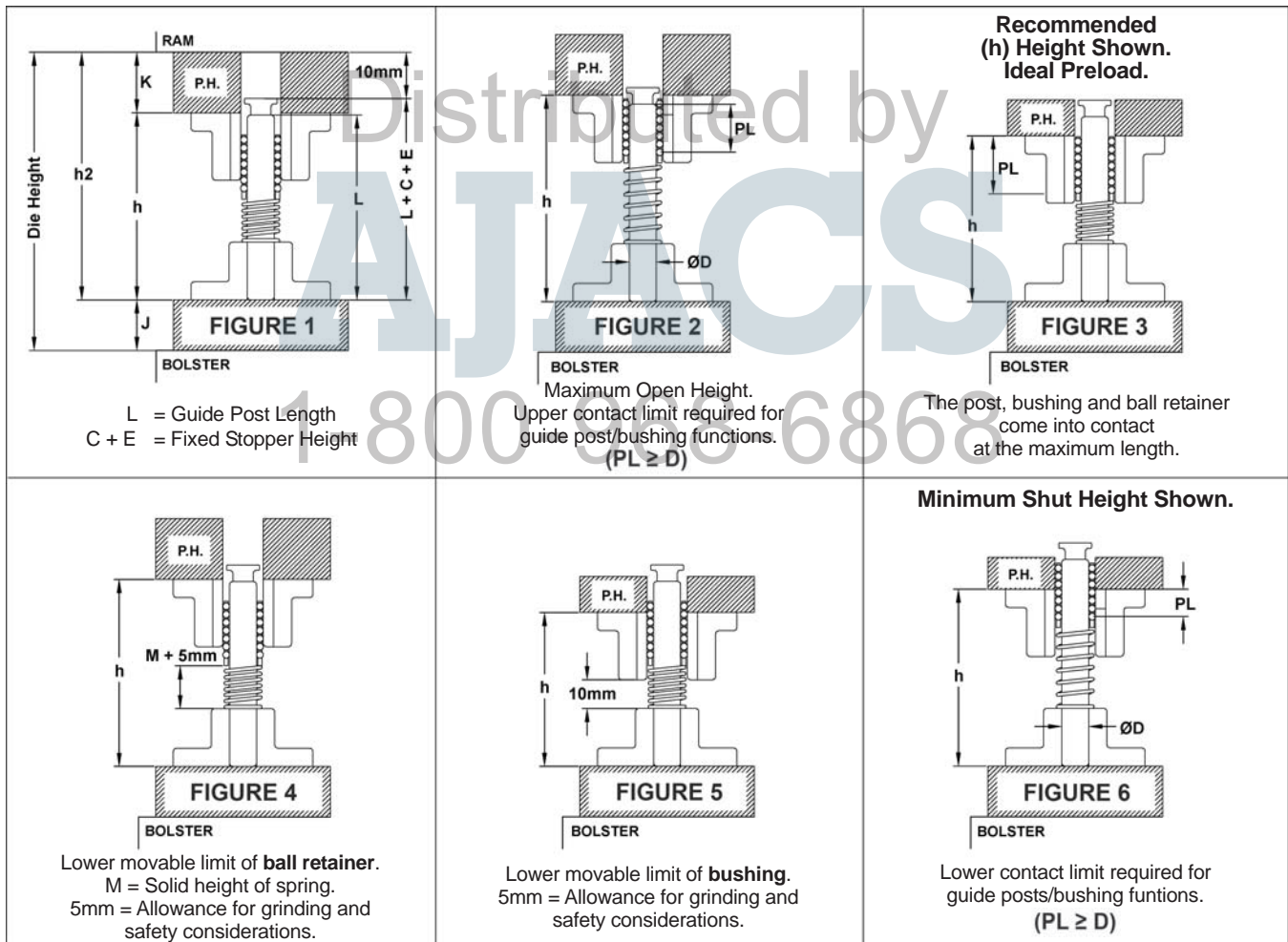

**K** = Punch Holder Thickness

**J** = Die Holder Thickness

**L** = Guide Post Length

**D** = Guide Post Diameter

**C + E** = Fixed Stopper Length

**PL** = Length of Ball Cage in Preload Condition

**M** = Spring Height to Solid

# Effective Fitting Range

Based on Conditions Shown on Page 3, Figs. 2 – 6

Post Size (D)(L)		Die Height (h)	100	120	140	160	180	200	220	240	260	280	300			h <sub>2</sub>
32	110			▲	★											150
	120		▲	●	★											160
	130		◆	●	★											170
	140		◆	●	★											180
	150		◆	●	★											190
	160		◆	●	★											200
	170		◆	●	★											210

Post Size (D)(L)		Die Height (h)	120	140	160	180	200	220	240	260	280	300	320	340	360	h <sub>2</sub>
38	130			▲	★											180
	140		▲	★												190
	150		◆	●	★											200
	160		◆	●	★											210
	170		◆	●	★											220
	180		◆	●	★											230
	200		■	●	★											250
	220			■	●	★										270
	240				■	●	★									290
	260					■	●	★								310
	300							■	●	★						350

Post Size (D)(L)		Die Height (h)	160	180	200	220	240	260	280	300	320	340	360	380	400	h <sub>2</sub>
50	170			▲	★											230
	180		▲	●	★											240
	200		◆	●	★											260
	220		◆	●	★											280
	240		◆	●	★											300
	260			■	●	★										320
	300				■	●	★									360
	350						■	●	★							410

Post Size (D)(L)		Die Height (h)	180	200	220	240	260	280	300	320	340	360	380	400	420	h <sub>2</sub>
60	200			▲	★											275
	220		▲	●	★											295
	240		◆	●	★											315
	260		◆	●	★											335
	280		◆	●	★											355
	300			■	●	★										375
	350					■	●	★								425

NOTE: Symbols shown in the above tables are for reference only.

- ★ (Fig. 2) Upper contact limit required on **open**
- (Fig. 3) **Ideal preload** recommended (h) shown
- ▲ (Fig. 4) Lower movable limit of **Ball Retainer**
- ◆ (Fig. 5) Lower movable limit of **Bushing**
- (Fig. 6) Lower contact limit required on **closed**

# Stroke End Blocks – Flat Type & Nesting Step Type

Nesting Step Type  
SEB5050R

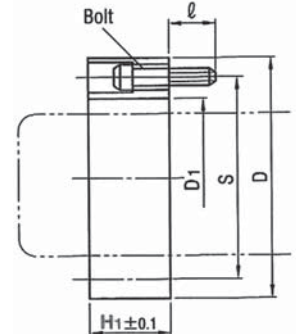
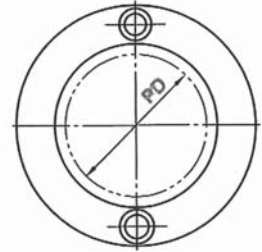

FLAT TYPE

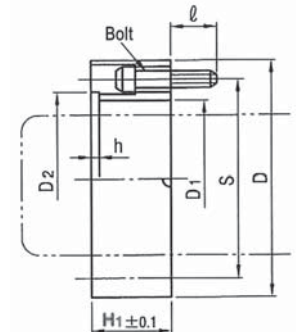
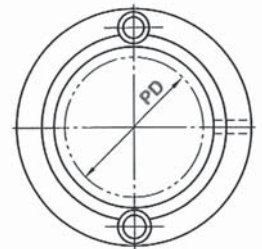

NESTING STEP TYPE

Anchor Dandy Part Number		PD	D	D1	D2*	S	h*	Bolt	l	H1
Flat Type	Nesting Step Type									
SEBA3210R	SEB3210R	32	56	41	45	45	2	M4xP0.7	10	10
SEBA3215R	SEB3215R									15
SEBA3220R	SEB3220R									20
SEBA3225R	SEB3225R									25
SEBA3230R	SEB3230R									30
SEBA3235R	SEB3235R									35
SEBA3240R	SEB3240R									40
SEBA3245R	SEB3245R									45
SEBA3250R	SEB3250R									50
—	SEB3255R									55
—	SEB3260R	60								
SEBA3815R	SEB3815R	38	72	49	56	60	3	M5xP0.8	10	15
SEBA3820R	SEB3820R									20
SEBA3825R	SEB3825R									25
SEBA3830R	SEB3830R									30
SEBA3835R	SEB3835R									35
SEBA3840R	SEB3840R									40
SEBA3845R	SEB3845R									45
SEBA3850R	SEB3850R									50
—	SEB3855R									55
—	SEB3860R									60
—	SEB3865R	65								
—	SEB3870R	70								
SEBA5020R	SEB5020R	50	86	62	68	72	3	M6xP1.0	10	20
SEBA5025R	SEB5025R									25
SEBA5030R	SEB5030R									30
SEBA5035R	SEB5035R									35
SEBA5040R	SEB5040R									40
SEBA5045R	SEB5045R									45
SEBA5050R	SEB5050R									50
—	SEB5055R									55
—	SEB5060R									60
—	SEB5065R									65
—	SEB5070R	70								
—	SEB5075R	75								
—	SEB5080R	80								
SEBA6020R	SEB6020R	60	112	76	84	92	3	M8xP1.25	12	20
SEBA6025R	SEB6025R									25
SEBA6030R	SEB6030R									30
SEBA6035R	SEB6035R									35
SEBA6040R	SEB6040R									40
SEBA6045R	SEB6045R									45
SEBA6050R	SEB6050R									50
—	SEB6055R									55
—	SEB6060R									60
—	SEB6065R									65
—	SEB6070R	70								
—	SEB6075R	75								
—	SEB6080R	80								

\* Dimensions for Nesting Step Block ONLY.