

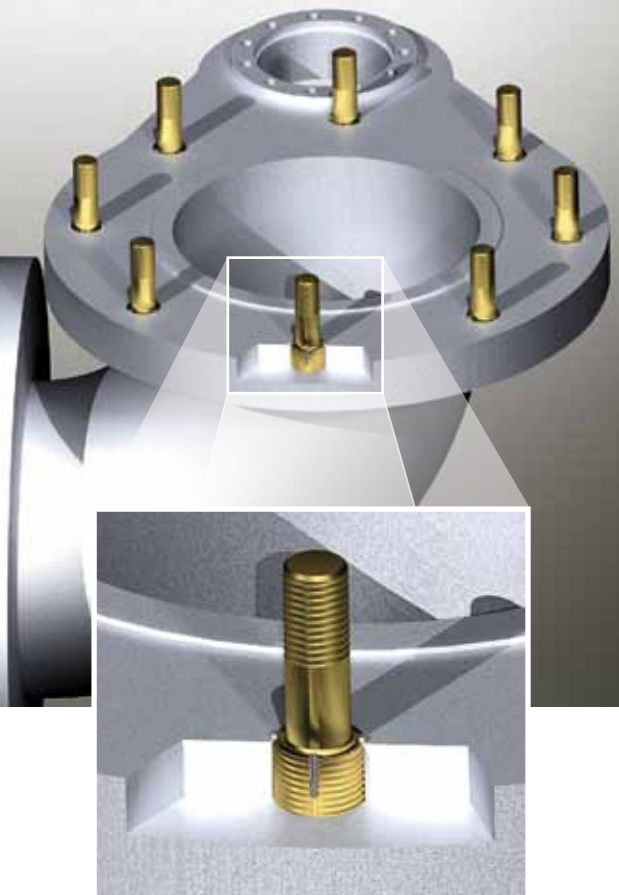

Keylocking Studs



- **Securely Locked with Keys**
- **Solid One-Piece Design Provides High Pull-Out Strength and Torque-Out Capabilities**
- **Ideal for OEM Use, Thread Repair or High Vibration Applications**

Acme Keylocking Studs provide security and “repairability” in applications where you can’t use a through-bolt/nut combination. They are superior for use in soft materials such as aluminum or magnesium when extra strength, extended thread life and vibration-resistance are required.



Acme Industrial Company

Subsidiary of Jergens, Inc.

441 Maple Avenue
Carpentersville, IL 60110

Tel: 847-428-3911
800-323-5582

Fax: 847-428-1820

www.acmeindustrial.com

Typical Applications Include:

Aerospace, electronics, automotive, industrial and military.
Found on engines, transmissions, housings.

Easy Installation With Standard Drills and Taps



1. Drill with a standard tap drill and countersink with a standard 82° - 100° countersink.



2. Tap new threads with a standard tap.



3. Screw in the stud end until it is .010-.030 below the surface. Keys locate the proper depth.



4. Drive keys down with several hammer taps on the proper installation tool.

Keylocking Studs

- Produced to NAS and SAE standards (MS51833 & MS51834)
- Full range of inch and metric sizes
- Available in 303, A286, and 17-4PH CRES and 4140 Alloy Steel
- Lightweight and heavy duty versions available
- Precision rolled UNJ threads allow transfer of high axial loads into base material

Removable!

If necessary, Acme Keylocking studs can be removed without damage to the parent material:

1. Cut the stud to be flush with parent material.
2. Drill out material between keys with a standard drill (drill bushing required) to specified depth.
3. Bend the keys inward and break off.
4. Remove the old stud using a screw extractor or similar device.
5. Install a replacement stud into the original tapped hole and drive keys down.



Short Lead Times, Competitive Prices, Top Quality, Made in USA

Rely on Acme's manufacturing expertise to provide the performance you expect from a supplier as evidenced by approvals from major worldwide aerospace manufacturers.

Since 1914, Acme Industrial has been a major force in supplying precision steel products to the manufacturing and military sectors. Now, Acme introduces its new **Acme Keylocking Stud** product line to the marketplace. These high-performing studs are engineered and manufactured to meet or exceed today's high quality requirements and demands.



ISO 9001:2000
Registered

Quality Management
System

Acme Industrial Company

Subsidiary of Jergens, Inc.

441 Maple Avenue
Carpentersville, IL 60110

Tel: 847-428-3911

800-323-5582

Fax: 847-428-1820

www.acmeindustrial.com