

CUMSA Marking Units

Available in 4 and 6 wheel units

The CUMSA Marking Unit from Dayton Progress features 3.8mm (.150") tall easy to read numbers to mark parts with date, part number, lot number or other numerical identifiers. Each wheel features numbers "0" thru "9" plus a blank providing multiple combinations. Available in 4 and 6 wheel configurations, it is a simple process to change the numbers in the self-contained unit.

The unit can be surface mounted in a die, mounted in a pocket, even cam mounted if you have an angular surface. Depth of penetration of the number can be adjusted by grinding or shimming the hard bottom plate of the unit. This allows for proper control of the appearance of the numbers when dealing with different materials.

The CUMSA number wheels are made of tool steel and fully hardened for a long service life. In the event a new wheel is needed, the change is a simple process.

What's in your number?



*For in-die stamping
numerical data
on parts*

Marking Units



Global leader in
quality metal fabrication
and stamping tools

Marking Units

- Traceability for sheet metal parts
- Available with 4 and 6 wheels
- Quick and easy change of wheel's position without removing from the die



UM

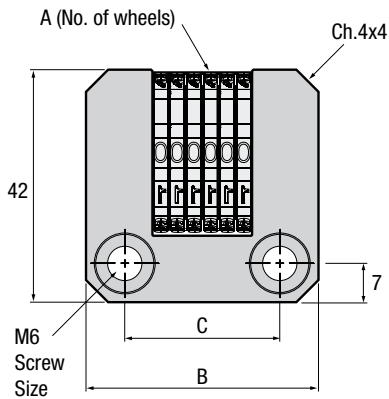
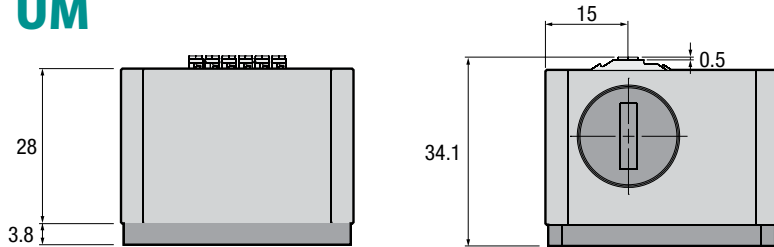

| Part No. | A | B | C |
|-----------|---|----|----|
| UM.043642 | 4 | 36 | 22 |
| UM.064242 | 6 | 42 | 28 |

HOW TO ORDER

Specify: Qty. Catalog No.
 Example: 2 UM 043642
 1 RR 180311

IMPORTANT

Max. 33.8

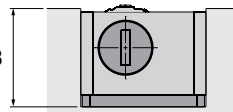

RR

Interchangeable Wheel

| Part No. | Tool Steel |
|-----------|------------|
| RR.180311 | HRC 56-59 |

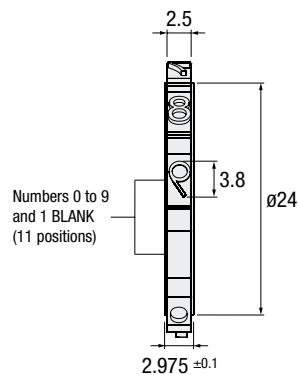
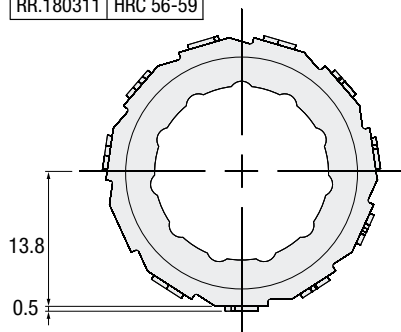

DAYTON PROGRESS CORPORATION • 500 Progress Road • P.O. Box 39 • Dayton, OH 45449-0039 • USA
 Telephone: 937-859-5111 • Fax: 937-859-5353 • www.daytonprogress.com

Form 8071 10/21