

# DAYStrip<sup>®</sup> Stripping System

Flat or Shaped Surface

**New!**



Long life, high stripping force, and solid quality make DAYStrip the ideal stripper. Three different sizes are available to fit most Dayton Progress retainers. DAYStrip strippers can be ordered semifinished (blanks) to be finished by customer.

## Superior Holding Strength

**Durable**  
**Self-contained**

**DAYStrip<sup>®</sup>**



Global leader in  
providing fabrication  
and stamping solutions

[www.daytonprogress.com](http://www.daytonprogress.com)

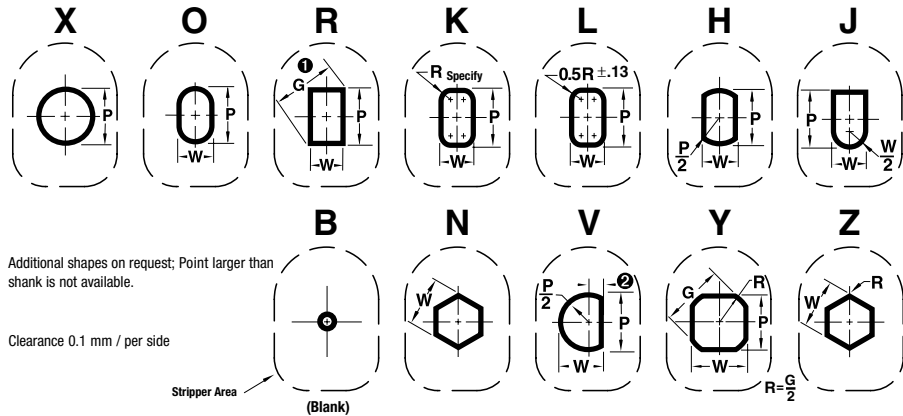
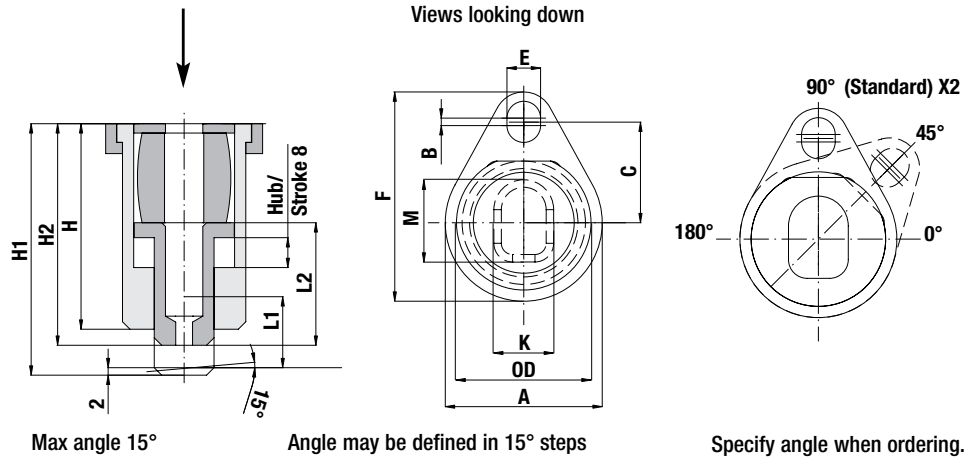
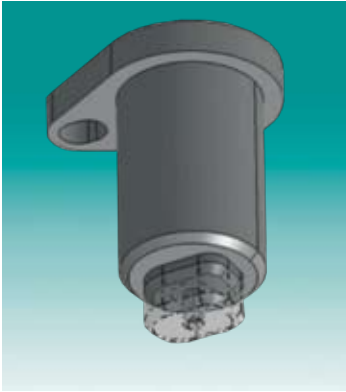

### Three types of DAYStrip strippers are available

Retainer	Punch Length	H	H1	L1	L2 min.	DAYStrip Type			Max Stroke
						UBG A	UBF A	UBE A	
ART/ARTS	80	45	56.3	19	22	•			8
ART/ARTS	90	45	66.3	19	32		•		8
CRT	80	45	56.3	19	22	•			8
CRT	90	45	66.3	19	32		•		8
BRT/BRTBS	90	45	56.3	19	22	•			8
BRT/BRTBS	100	55	66.3	19	32			•	8

The L2 blank length of 35 and 45 mm can be shortened upon request.

### Urethane

D	Type	Size	Force N
10	UU 10	20 x 32	1579
13	UU 13	25 x 32	2246
16	UU 16	28 x 32	2713
20	UU 20	32 x 32	3345
25	UU 25	40 x 32	5710
32	UU 32	45 x 32	3630
38	UU 38	52 x 32	5260
40	UU 40	52 x 32	5260

#### HOW TO ORDER

Example: UU 13

### Deflection

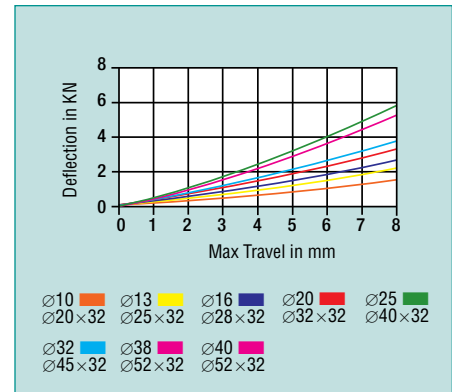

# Stripper Body

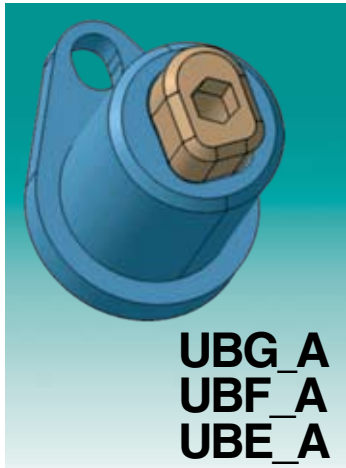

Shank Diameter	A	B	C	F	OD	K	M	E	Force N
10	42	2	27.00	56	33	16	22	9	1579
13	48	2	29.97	62	38	20	27	9	2246
16	52	2	31.75	66	43	23	32	9	2713
20	60	2	33.53	73	50	30	36	9	3345
25	70	2	40.64	83	60	40	46	9	5710
32	74	2	41.14	95	68	45	50	9	3630
38	84	2	44.49	95	77	50	54	9	5260
40	84	2	44.49	95	77	50	54	9	5260

## Assembly Type UBG\_A with Shape

D	Type	Range P	Type	Shape		L2	L2 min.*
				Min. W	Max. P/G		
10	UBGXA	2.10 – 9.97	UBG_A	2.10 – 9.97		35	22
13	UBGXA	4.50 – 12.97	UBG_A	4.50 – 12.97		35	22
16	UBGXA	6.00 – 15.97	UBG_A	6.00 – 15.97		35	22
20	UBGXA	8.00 – 19.97	UBG_A	8.00 – 19.97		35	22
25	UBGXA	10.00 – 24.97	UBG_A	10.00 – 24.97		35	22
32	UBGXA	12.50 – 31.97	UBG_A	12.50 – 31.97		35	22
38	UBGXA	14.00 – 37.97	UBG_A	14.00 – 37.97		35	22
40	UBGXA	14.00 – 39.97	UBG_A	14.00 – 39.97		35	22

## Assembly Type UBF\_A with Shape

D	Type	Range P	Type	Shape		L2	L2 min.*
				Min. W	Max. P/G		
10	UBFXA	2.10 – 9.97	UBF_A	2.10 – 9.97		45	32
13	UBFXA	4.50 – 12.97	UBF_A	4.50 – 12.97		45	32
16	UBFXA	6.00 – 15.97	UBF_A	6.00 – 15.97		45	32
20	UBFXA	8.00 – 19.97	UBF_A	8.00 – 19.97		45	32
25	UBFXA	10.00 – 24.97	UBF_A	10.00 – 24.97		45	32
32	UBFXA	12.50 – 31.97	UBF_A	12.50 – 31.97		45	32
38	UBFXA	14.00 – 37.97	UBF_A	14.00 – 37.97		45	32
40	UBFXA	14.00 – 39.97	UBF_A	14.00 – 39.97		45	32

## Assembly Type UBE\_A with Shape

D	Type	Range P	Type	Shape		L2	L2 min.*
				Min. W	Max. P/G		
10	UBEXA	2.10 – 9.97	UBE_A	2.10 – 9.97		45	32
13	UBEXA	4.50 – 12.97	UBE_A	4.50 – 12.97		45	32
16	UBEXA	6.00 – 15.97	UBE_A	6.00 – 15.97		45	32
20	UBEXA	8.00 – 19.97	UBE_A	8.00 – 19.97		45	32
25	UBEXA	10.00 – 24.97	UBE_A	10.00 – 24.97		45	32
32	UBEXA	12.50 – 31.97	UBE_A	12.50 – 31.97		45	32
38	UBEXA	14.00 – 37.97	UBE_A	14.00 – 37.97		45	32
40	UBEXA	14.00 – 39.97	UBE_A	14.00 – 39.97		45	32

Specify L2 when ordering

# Bronze-Graphite Insert



**UBGX**

## Bronze-Graphite Insert L2 = 35

D	Type	Range P	Type	Shape		L2	L2 min.
				Min. W	Max. P/G		
10	UBGX	2.10 – 9.97	UBG_	2.10 – 9.97		35	22
13	UBGX	4.50 – 12.97	UBG_	4.50 – 12.97		35	22
16	UBGX	6.00 – 15.97	UBG_	6.00 – 15.97		35	22
20	UBGX	8.00 – 19.97	UBG_	8.00 – 19.97		35	22
25	UBGX	10.00 – 24.97	UBG_	10.00 – 24.97		35	22
32	UBGX	12.50 – 31.97	UBG_	12.50 – 31.97		35	22
38	UBGX	14.00 – 37.97	UBG_	14.00 – 37.97		35	22
40	UBGX	14.00 – 39.97	UBG_	14.00 – 39.97		35	22

### HOW TO ORDER

Example:  
UBGR 13 P10.0 W5.0 L2 25\*\*

\*\* L2: Bronze-Graphite Insert shorter than standard (L2 Min. Note minimum lengths)



**UBFX**

## Bronze-Graphite Insert L2 = 45

D	Type	Range P	Type	Shape		L2	L2 min.
				Min. W	Max. P/G		
10	UBFX	2.10 – 9.97	UBF_	2.10 – 9.97		45	32
13	UBFX	4.50 – 12.97	UBF_	4.50 – 12.97		45	32
16	UBFX	6.00 – 15.97	UBF_	6.00 – 15.97		45	32
20	UBFX	8.00 – 19.97	UBF_	8.00 – 19.97		45	32
25	UBFX	10.00 – 24.97	UBF_	10.00 – 24.97		45	32
32	UBFX	12.50 – 31.97	UBF_	12.50 – 31.97		45	32
38	UBFX	14.00 – 37.97	UBF_	14.00 – 37.97		45	32
40	UBFX	14.00 – 39.97	UBF_	14.00 – 39.97		45	32

### HOW TO ORDER

Example:  
UBFB 13 L2 45

## Retainer/Stripper Combinations

L2	Retainer Type	Punch Lengths	Order
35	CRT	80	UBG_
45	CRT	90	UBF_
35	BRT	90	UBG_
45	BRT	100	UBF_
35	ART/ARTS	80	UBG_
45	ART/ARTS	90	UBF_

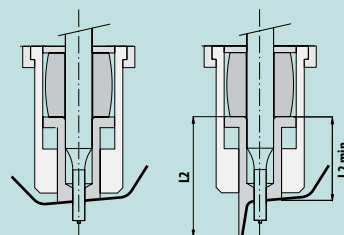

## Stripper Insert with Part Surface

Contoured stripper inserts are available in lengths of 35 and 45 mm.

The insert is manufactured to specifications in your CAD file or drawing/print.

The maximum angle is 15°.

Note the minimum lengths.

# Assemblies & Ordering Information

## Ball Lock

All angles are defined for reflected views of the punch. The head flat of the DAYStrip aligns with the ball seat. If a different angle is defined, the outer shape of the bronze-graphite insert rotates with the shape.

A rotation of the cutting shape to the outer shape of the bronze-graphite insert can be ordered as a special item based on your drawing or print. Standard angles are available in 15° steps. Intermediate angles are also possible.

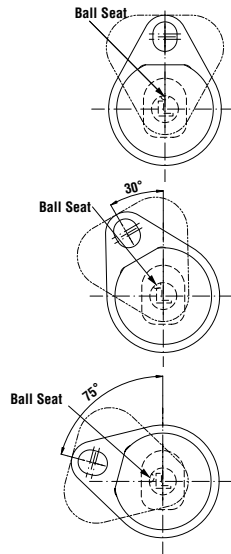

### HOW TO ORDER

Example:  
**DAYStrip:** UBGCA 16 C81 P6.0 W5.5 A2 B1 PP2.57 WW2.5 X2 90° L2 22  
**Punch:** BPC 16 1990 M2 C81 P6.0 W5.5 A2 B1 PP2.57 WW2.5

### HOW TO ORDER

Example:  
**DAYStrip:** UBGCA 16 C81 P6.0 W5.5 A2 B1 PP2.57 WW2.5 X5 120° L2 22  
**Punch:** BPC 16 1990 M2 C81 P6.0 W5.5 A2 B1 PP2.57 WW2.5 BS 120°

### HOW TO ORDER

Example:  
**DAYStrip:** UBGCA 16 C81 P6.0 W5.5 A2 B1 PP2.57 WW2.5 X5 165° L2 22  
**Punch:** BPC 16 1990 M2 C81 P6.0 W5.5 A2 B1 PP2.57 WW2.5 BS 165°

Punch	DAYStrip	
BS	0°	X2 0°
BS	15°	X5 15°
BS	30°	X5 30°
BS	45°	X5 45°
BS	60°	X5 60°
BS	75°	X5 75°

Punch	DAYStrip	
BS	90°	X2 90°
BS	105°	X5 105°
BS	120°	X5 120°
BS	135°	X5 135°
BS	150°	X5 150°
BS	165°	X5 165°

Punch	DAYStrip	
BS	180°	X2 180°
BS	195°	X5 195°
BS	210°	X5 210°
BS	225°	X5 225°
BS	240°	X5 240°
BS	255°	X5 255°

Punch	DAYStrip	
BS	270°	X2 270°
BS	285°	X5 285°
BS	300°	X5 300°
BS	315°	X5 315°
BS	330°	X5 330°
BS	345°	X5 345°

## Press Fit

All angles are defined for reflected views of the punch. The head flat of the DAYStrip is 90° to the key flat of the punch. If a different angle is defined, the outer shape of the bronze-graphite insert rotates with the shape.

A rotation of the cutting shape to the outer shape of the bronze-graphite insert can be ordered as a special item based on your drawing or print. Standard angles are available in 15° steps. Intermediate angles are also possible.

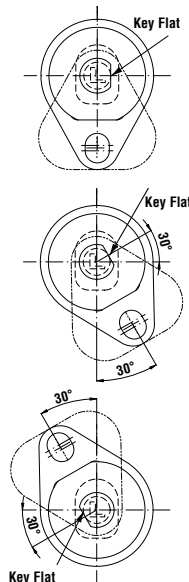

### HOW TO ORDER

Example:  
**DAYStrip:** UBFGA 16 C81 P6.0 W5.5 A2 B1 PP2.57 WW2.5 X2 270° L2 22  
**Punch:** APC 16 1990 M2 C81 P6.0 W5.5 A2 B1 PP2.57 WW2.5

### HOW TO ORDER

Example:  
**DAYStrip:** UBFGA 16 C81 P6.0 W5.5 A2 B1 PP2.57 WW2.5 X5 300° L2 22  
**Punch:** APC 16 1990 M2 C81 P6.0 W5.5 A2 B1 PP2.57 WW2.5 X5 30°

### HOW TO ORDER

Example:  
**DAYStrip:** UBFGA 16 C81 P6.0 W5.5 A2 B1 PP2.57 WW2.5 X5 120° L2 22  
**Punch:** APC 16 1990 M2 C81 P6.0 W5.5 A2 B1 PP2.57 WW2.5 X5 210°

Punch	DAYStrip	
X2	0°	X2 270°
X5	15°	X5 285°
X5	30°	X5 300°
X5	45°	X5 315°
X5	60°	X5 330°
X5	75°	X5 345°

Punch	DAYStrip	
X2	90°	X2 0°
X5	105°	X5 15°
X5	120°	X5 30°
X5	135°	X5 45°
X5	150°	X5 60°
X5	165°	X5 75°

Punch	DAYStrip	
X2	180°	X2 90°
X5	195°	X5 105°
X5	210°	X5 120°
X5	225°	X5 135°
X5	240°	X5 150°
X5	255°	X5 165°

Punch	DAYStrip	
X2	270°	X2 180°
X5	285°	X5 195°
X5	300°	X5 210°
X5	315°	X5 225°
X5	330°	X5 240°
X5	345°	X5 255°